

INTERNET OF THINGS (IOT) WITH IMPROVED SECURITY FOR MALACCA CHALET

Yuseni Ab Wahab¹, Hairul Hazlina Mohd Ali².

¹ Kolej Universiti Islam Melaka (KUIM),
Kuala Sungai Baru 78200, Masjid Tanah, Melaka
² Melaka State Department of Education Malaysia
Ministry of Education Malaysia,

¹yuseni@kuim.edu.my, ²mhairulhazlina@gmail.com

Article history:

Received : 26 November 2021

Accepted : 7 January 2022

Published : 24 January 2022

Abstract

Modern-day Malacca is a vibrant old city with a unique historical and cultural background from being the capital of a powerful Malay kingdom before the colonial era, as well as subsequent Portuguese, Dutch and British rule. The city centre was listed by UNESCO as a World Heritage Site in July 2008, many tourists come to Malacca to visit historical sites and tourism, Chalet facilities should be provided for families and travellers for accommodation in their residence in the chalet. In this study, propose a smart digital door lock system chalet system. A digital door lock system is equipment that uses the digital information such as a secret code, semi-conductors, smart card, and finger prints as the method for authentication instead of the legacy key system. In proposed system, a ZigBee module is embedded in digital door lock and the door lock acts as a central main controller of the overall homestay system. A door lock system proposed here consists of RFID reader for user authentication, touch LCD, motor module for opening and closing of the door, sensor modules for detecting the condition inside the house, communication module, and control module for controlling other modules. Status of individual ZigBee module can be monitored and controlled by the centralized controller, digital door lock. As the door lock is the first and last thing people come across in entering and leaving the homestay respectively, the Chalet automation function in digital door lock system enables user to conveniently control and monitor chalet environment and condition all at once before entering or leaving the house stay. Furthermore, it also allows users to remotely monitor the condition inside the house through Internet or any other public network.

Keywords-; Homestay system; ZigBee module; RFID reader

I. INTRODUCTION

The Chalet System is a computerized computer network, designed to monitor and control chalet appliances and homestay lighting systems. It allows users to remotely monitor and control consumer electronics via the Internet [1]. Homestay automation is a new field that has attracted attention in the area of inquiry. Although wired homestay networks are well known for the early development of homestay automation systems, Figure 1 shows a comparison between typical wired home servers and the recommended digital door smart lock system [2].

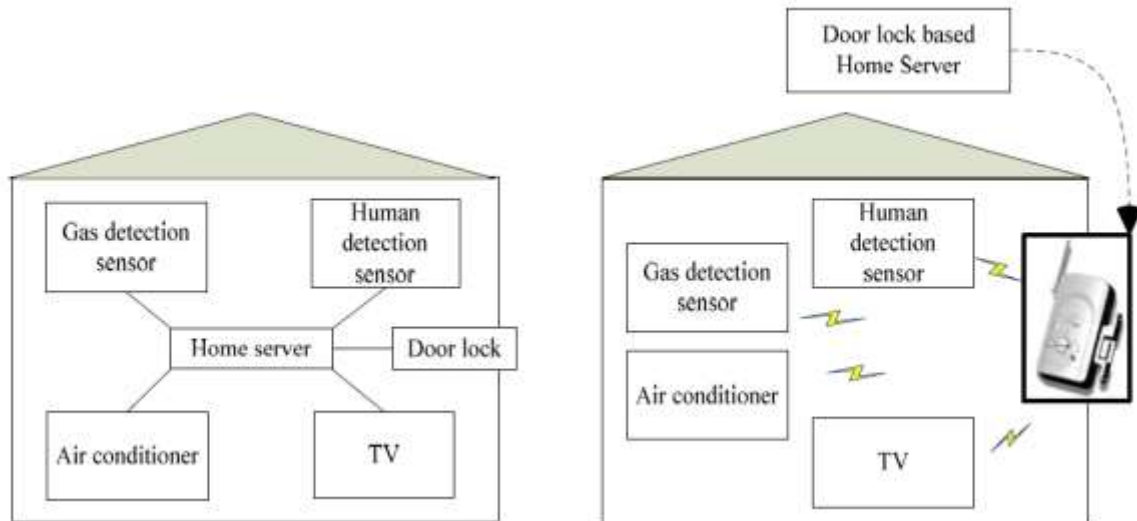

Figure 1. Proposed smart door lock based server system.

As shown in figure 1, wired systems require appropriate planning and construction work for efficient and clean design. That's why wireless communication replaces the wired person. In addition, wireless systems provide more flexibility and continuity [3]. That is, the installation is free from construction work because it does not require cabling. Although many wireless network solutions such as Bluetooth, Wireless Ethernet, and more, are in the field of homestay networks, ZigBee, a newly developed protocol for wireless sensor network specifications, has been the most exciting technique in the field of research as it fits for system environment, which requires less power consumption and lower rate data requirements. Furthermore, it builds up home automation by providing the master control panel for major home appliances and lighting system at digital door lock and switching the home appliances on/off depending on people presence and absence. In this work, we have taken ZigBee network as the backbone of our system [4].

The propose a digital door lock based homestay automation system, which exploits the full capacity of ZigBee sensor network by integrating home security with home automation. In proposed system, a ZigBee module is embedded in digital door lock and the door lock acts as the central main controller of the entire system. The proposed system is the network of sensor nodes with digital door lock as base station. Sensor nodes are deployed at appropriate places at homestay [5]. Furthermore, ZigBee modules accompanied by ZigBee relay module are attached to the major homestay appliances for controlling the power condition. The entire network can be monitored and controlled through the digital door lock. As the door lock is the first and last thing people come across while entering and leaving the home respectively, the homestay automation function in digital door lock system enables user to control and monitor home environment and condition from a single master control panel before entering or leaving the house. Furthermore, it also allows users to remotely monitor the condition inside the house through Internet or any other public network [6], [7].

II. PROPOSED SMART DIGITAL DOOR LOCK SYSTEM

In this study will provide a brief description of the proposed system followed by ZigBee module operation, digital door lock and sensor module. The use of the term ZigBee module to refer to the communication module, sensor node to refer to an integrated node consisting of sensors, actuators, and other additional circuits.

A. System description

The smart digital door lock is a system for monitoring and controlling some devices in homestay. The smart digital door lock system operates through a wireless sensor network. It is a sensor node network with digital door lock as a sink node as shown in Figure 1. Smart digital smart lock system can be divided into five parts: control module, motor module, sensor module, communication module and I / O module. The control module consists of the MCU embedded in the digital door lock, the brain of the system. The locking operation is controlled by the motor module. The communication module is for communication between device and control module [8]. Users can access door lock system via I / O module. I / O module includes RFID reader and digital dial pad for verification, TFT Touch LCD to control individual devices and display related information. Once the user is confirmed by the system, the user can monitor and control the home appliances from the central control panel. To interact with visitors, door locks come with camera modules, microphones, and speakers. Touch LCD is provided on both sides of the door. Therefore, users can monitor and interact with other visitor's door through this device [9]-[16].

B. ZigBee Module

The ZigBee module includes RF communication modules and is used in digital door locks and sensor nodes. Figure 2 shows the ZigBee module structure installed on homestay equipment. The main component of the ZigBee module is the ZigBee and MCU transceivers. ZigBee transceivers use commercial RF chips, which have modems to implement the IEEE802.15.4 medium and MAC (IEEE802.15.4) physical access layer (PHY) operating at 2.4 GHz. The MCU is the controller, which controls the ZigBee transceiver, and implements the program [3]. ZigBee contains program memory to implement MAC, network layer, and application layer. Whereas the PHY and MAC layers from the ZigBee stack architecture follow the proposed IEEE802.15.4, the application layer interface is defined by the ZigBee Alliance table.

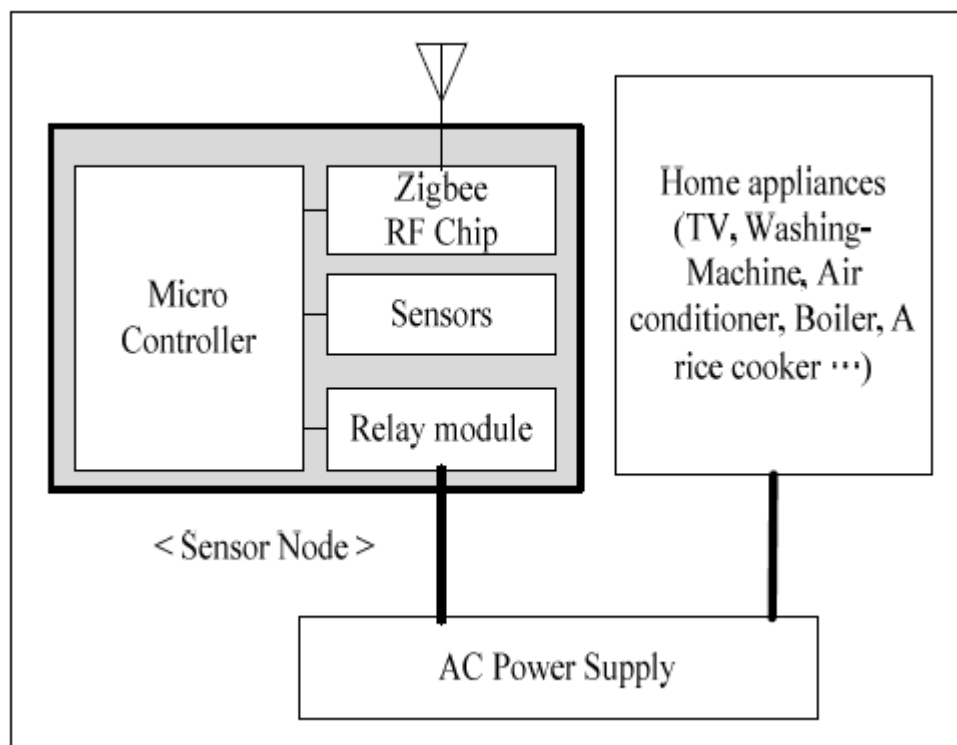

Figure 2. ZigBee module connected to home appliances.

C. Digital Door Lock

Control modules, I / O modules, and motor modules are inside the digital door lock. The digital door lock structure and component connectivity are shown in Figure 3. The digital door lock consists of the main processor, ZigBee module, door lock controller, CDMA module, camera module, card reader, microphone, and speaker. The control module is the brain of the system. The control module performs two main functions. First, it controls the door lock. And secondly, it controls and monitors the entire network. Lock / open lock in door lock controller activates digital door lock for open / close operation. The control module controls the motor drive circuit that operates the motor as a drive. Card reader is used for verification even RFID cards and tags. Touch lenses are used to enter and change password verification, change sensor node settings, and also to display relevant information on the screen. The ZigBee module in the digital door lock is the interface between the sensor node and the control module. The information between sensor nodes and control modules is changed through the ZigBee module [10]. The CDMA module is used to tell users about emergencies via short message services (SMS) and multimedia messaging services (MMS). And finally, microphones, speakers and camera modules are used for interaction between visitors and users before opening the door.

D. Sensor Module

Sensor nodes are assigned two main tasks. The first task is to monitor the surrounding environment around the homestay and the second task is to change the power status of homestay devices. To monitor environmental conditions, such as temperature, gas leakage, theft, fire, etc., appropriate sensors are attached to the ZigBee module. For devices whose power status needs to be controlled, the ZigBee module is included with the ZigBee relay module in the sensor node as shown in Figure 2. The ZigBee relay module is used to switch on or turn off home appliances. Sensor nodes continue to upload their current status and relevant data to digital doors. Also, the sensor node sends response messages including operating results, as there are instructions from the digital door lock[10],[11].

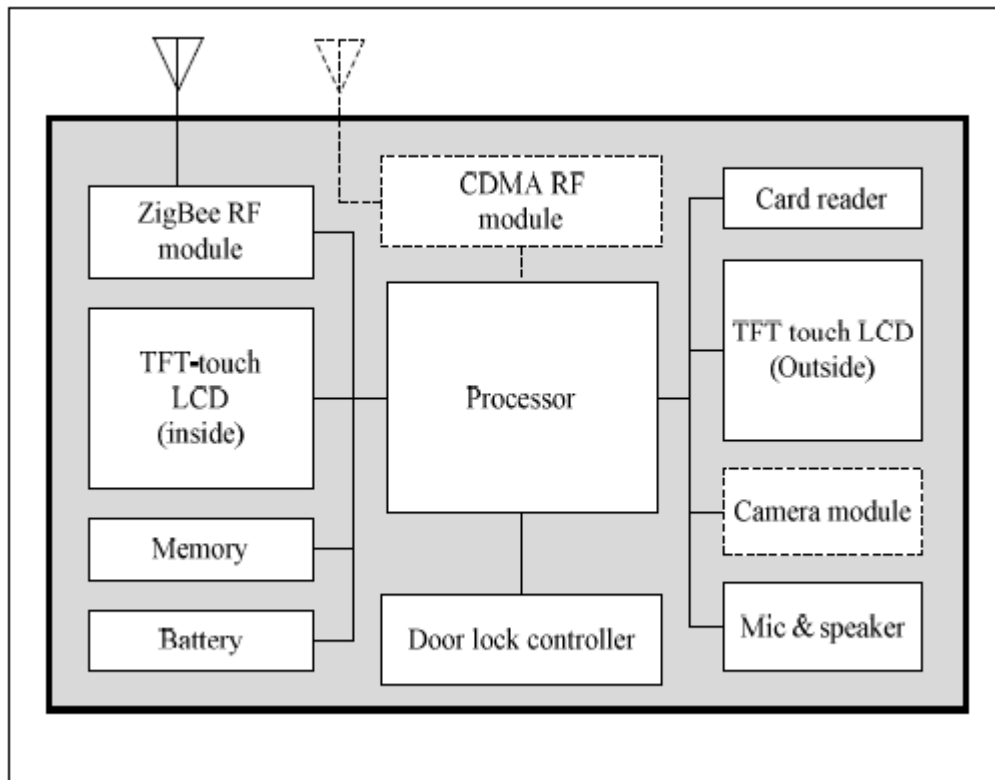

Figure 3. Structure of digital door lock.

III. OPERATION SMART DIGITAL DOOR LOCK SYSTEM

A. Communication

Smart digital door lock system works in two communication modes: centralized mode and emergency mode. In centralized mode, digital door takes the control of overall communication in the network and sensor nodes act accordingly as instructed by door lock. This type of communication is generally done in normal situation when everything is all right. This communication mode reduces unnecessary communication between sensor nodes and central controller and also saves energy consumptions. Upon detection of the emergency mode by the sensor node, the respective action is taken such as releasing water for fire, turning buzzer on for burglary and immediately that event is reported to the door lock without any initiation from door lock[17],[18]. Door lock in turn reports the event to the end user through SMS or MMS.

IV. Smart Digital Door Lock System

Once the person is authenticated through password or RFID tag, the door lock is opened and the LCD displays the status of different appliances in the home. User can choose to change the current status of the appliances or leave them as it is. For the convenience of the end user, our system can operate in two operational modes: manual and automatic. Smart digital door lock system can have three events: person entering the home, person leaving, and the emergency situation as shown in Fig. 4. Both operational modes will be explained on the base of these events.

C. Modes of Operation

1) **Outgoing Event** Fig. 5 shows the flow chart for outgoing event i.e., the case of person leaving the home. As digital door lock is the last thing user will encounter before leaving the house, when the user presses the door lock button, door lock request all sensors (Table),

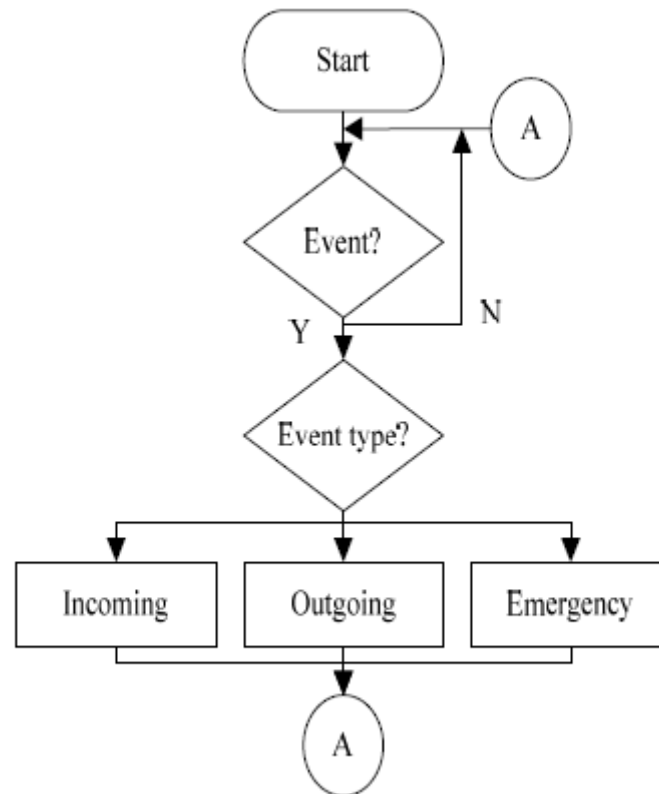

Figure 4. Events in smart digital door lock system

to send their fresh status and the touch LCD displays them on the screen. Initially, the system enters into the manual mode. In manual modes, users can choose from the menu which home appliance to turn on/off manually. With manual mode in operation, the users now don't have to bother of checking the status of individual home appliances physically. He can leave everything as it is in his room and finally select which devices to turn on or off from the door. If user finds that TV is on, he can turn it off from the door. If the user did not touch LCD screen for certain amount of time after locking the door, then the system enters into automatic mode. For automatic mode to work, we have to set the priority setting of device beforehand. The priority setting here means deciding which device should be on or off in the absence of user. The device with priority 1 means it should remain on and priority 0 means should be turned off.

Therefore, user decides which device should be turned on and off in his absence through the touch LCD screen. This is one time process but can be done any time when felt necessary. Therefore, when the system enters into automatic mode, it turns off all those devices which priority is 0 if it is still on. With the implementation of this mode, now user doesn't need to bother about the power status of the devices in his room whenever he leaves the home. He can leave lights and TV on when leaving the home. Our system eventually switches them off [12][19].

2) **Incoming Event** Fig. 6 shows flow chart for incoming event i.e., person entering the home. Incoming event can also be operated in manual and automatic mode. After being authenticated, the system unlocks the door. Then the system requests the fresh status of all devices and checks for the emergency situation.

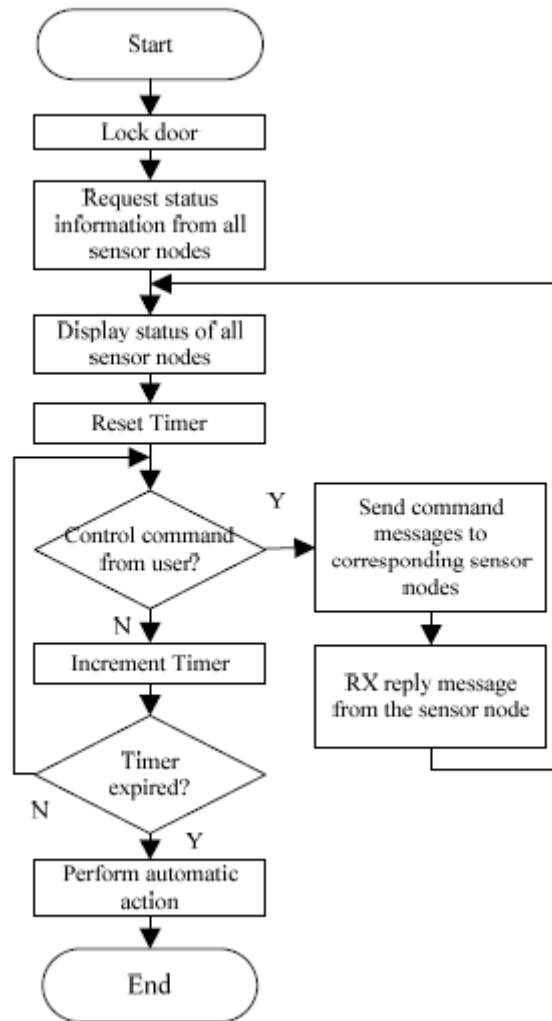

Figure 5. Flow chart for outgoing event.

If there has been some emergency situation, the corresponding emergency message such as fire, burglary, and various other alert messages are displayed on LCD. In other case user can see the status of the room in the touch LCD. The current environmental condition of home can be easily viewed in the LCD. In the manual mode user can switch on/off the individual device though the touch LCD [13]. Suppose he finds the room is hot, thus he can switch on the air conditioner though the LCD. If the user did not touch LCD screen for a certain amount of time after unlocking the door, then our system enters into automatic mode. Here also, for automatic mode to work, we have to set the priority setting of devices. Priority here is not the same with the priority used in previous outgoing event. Therefore, the system stores two priorities information for individual device. Here, the device with priority 1 means it should be on and priority 0 means should remain off. This is also one time process but can be done any time when felt necessary. Therefore, when the system enters into automatic mode, it turns on all those devices which priority is 1 if it is still off. User can set priority of devices such as air conditioner and TV to 1 so that they are on as soon as user is at home.

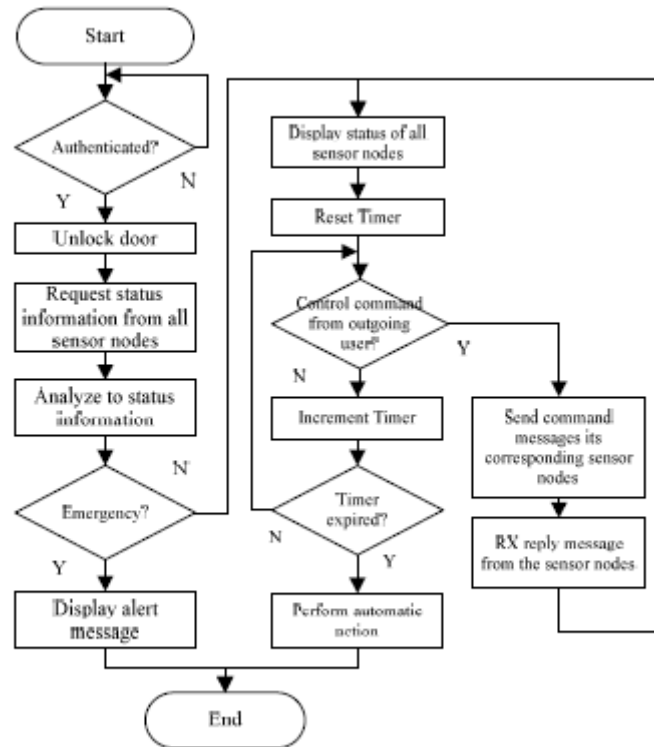

Figure 6. Flow chart incoming event.

3. Emergency Event

The system may encounter emergency situation such as burglary, fire and so on. Fig. 7 shows the flow chart of emergency situation for both sensor nodes and digital door. Fig. 7(a) is a flow chart for sensor node whereas the Fig. 7(b) is for digital door lock. On detecting the emergency situation by sensor node, the corresponding information is immediately notified to the door lock. Also, at the meantime, the sensor node triggers the actuators for handling the current emergency situation. At the door lock side, after being informed about the emergency situation, the door lock sends the SMS to the user notifying about the situation. The system also triggers the alarm. For example, sensor node, perceived when gas leaked, transmits current situation through a door-lock, downs the power of electric home appliances connected to nodes by conveying a signal[20].

4) Relay Node

Relay nodes use smart digital home servers, expecting homestay automation to be satisfied. But there is still a problem of attenuation of RF signals that often occur in closed environments such as homestay. This unreliable RF signal will worsen in a micro-oven and consumer electronics house that uses the same frequency band. To support the transmission of reliable RF signals, we construct the ZigBee RF repeater arranged at the entrance of each room. Also, this node can be used to lock and open the door of each room [14]

VI. DESIGN OF SMART DIGITAL DOOR LOCK SYSTEM

The prototype system is implemented for chalet automation based on digital door locks with the ZigBee network protocol. Figure 8 shows the implementation of a smart centre controller

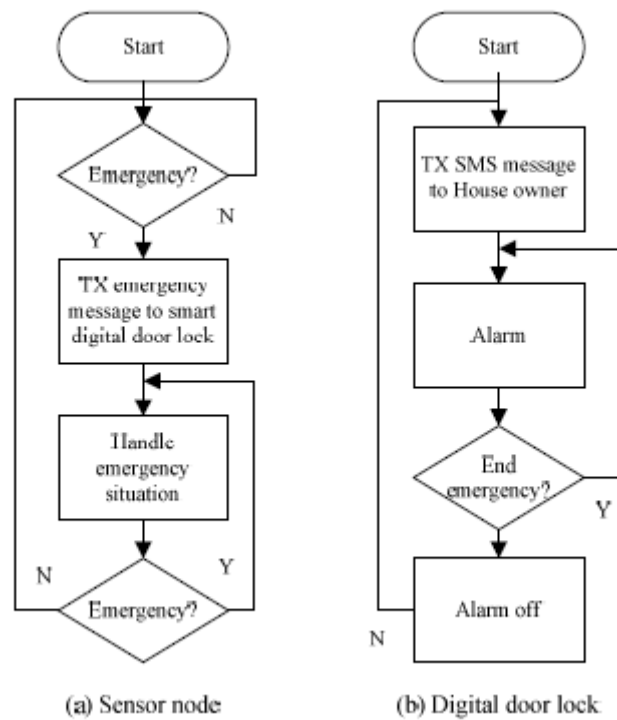

Figure 7. Flow chart for emergency event.

Digital door lock system. Select and modify one of the commercial door lock products. All control circuits for locking and unlocking doors have been rebuilt into our ZigBee-based AVR controller system. Interface between user and system is provided by touch LCD. Figure 9 shows a touch LCD snap shot. Figure 9 (a) shows the interface for user authentication. Input the password user for authentication through this interface. Similarly, in Figure 9 (b), the LCD displays the state of the home. Users can monitor and control the home environment from this interface. Figure 10 shows our switch module used to convert consumer electronics at home. As shown in the picture, the ordinary electric adapter is connected to the ZigBee relay module installed on the sensor node. This switching module is used to turn on and off the power according to instructions issued from the digital door lock server [15].



Figure 8. The door lock back view.



(a) Authentication (b) System display

Figure 9. The door lock LCD interface



Figure 10. Sensor node with power switching module.

VII. CONCLUSION

In this study, delivered novel homestay automation systems based on ZigBee integrating homestay security. The proposed system exploits ZigBee's full ability to monitor and control the environment and homestay conditions through digital door locks.

REFERENCES

- [1] ZigBee Alliance Document 053474r06, ZigBee Specification, v. 1.0, Dec 2014.
- [2] F. L. Zucatto, C.A. Biscassi, F. Monsignore, F. Fidelix, S. Coutinho, and M. L. Rocha, "ZigBee for Building Control Wireless Sensor Networks," in proceeding of Microwave and Optoelectronics Conference, pp. 511- 515, Oct. 2015.
- [3] Il-Kyu Hwang and Jin-Wook Baek, "Wireless Access Monitoring and Control System based on Digital Door Lock," IEEE Trans. On Consumer Electronics, Vol. 53,2016
No. 4, Nov. 2007. pp 1724-1730. [4] A. Wheeler, "Commercial Applications of Wireless Sensor Network Using ZigBee", IEEE Communications Magazine, V. 45, N. 4, pp.:70 – 77, April 2017.
- [5] Eaton Corp., "Eaton Home Heartbeat,"
<http://www.homeheartbeat.com/HomeHeartBeat/index.htm>.
- [6] <http://www.ZigBee.org>
- [7] Ahsan M, Talib MR, Sarwar MU, Khan MI, Sarwar MB (2016) Ensuring interoperability among heterogeneous devices through IoT middleware. Int J Comput Sci Inf Secur 14(4):251–255Google Scholar
- [8] Aijaz A, Su H, Aghvami AH (2015) CORPL: A routing protocol for cognitive radio enabled AMI networks. IEEE Trans Smart Grid 6(1):477–485
- [9] Al-Fuqaha A, Guizani M, Mohammadi M, Aledhari M, Ayyash M (2015) Internet of things: a survey on enabling technologies, protocols, and applications. IEEE Commun Surveys Tutor 17(4):2347–2376
- [10] Dandelski C, Wenning BL, Perez DV, Pesch D et al (2015) Scalability of dense wireless lighting control networks. IEEE Commun Mag 53(1):157–1654.
- [11] Desai P, Sheth A, Anantharam P (2015) Semantic gateway as a service architecture for IoT interoperability. In: IEEE international conference on mobile services, 2015, pp 313–319
- [12] Dujovne D, Watteyne T, Vilajosana X, Thubert P (2014) 6tisch: deterministic ip-enabled industrial internet (of things). IEEE Commun Mag 52(12):36–41C
- [13] Elkhodr M, Shahrestani S, Cheung H (2016) The internet of things: New interoperability, management and security challenges.
- [14] Evans D (2011) The internet of things. how the next evolution of the internet is changing everything, whitepaper. Cisco Internet Business Solutions Group (IBSG)
- [15] Gubbi J, Buyya R, Marusic S, Palaniswami M (2013) Internet of things (IoT): a vision, architectural elements, and future directions. Future Gener Comput Syst 29(7):1645–1660
- [16] Y. A. Wahab and A.S.H. Basari. (2013). "Analysis of down time and reliability estimation in hostel building maintenance-a case study,"Middle-East Journal of Scientific Research, Vol. 17, no. 9, pp.1260-1268.
- [17]Y. A. Wahab and A.S...H Basari. (2014). Identifying the best parameter distribution for university hostel building maintenance" Middle-East Journal of Scientific Research 22 (8): 1145-1149, 2014.ISSN 1990- 9233 © IDOSI Publications.
- [18]Y. A. Wahab and A.S..H Basari. (2014). „Replacement model for hostel building case study: ICYM" Middle-East Journal of Scientific Research 21 (11): 1977-1981, 2014 ISSN 1990-9233 © IDOSI Publications.

[19] Y. A. Wahab and A.S.H Basari. (2015), „Best parameter of the hostel building component maintenance“ International Journal of Computer Applications (0975 – 8887) Vol. 110 – No. 15, January 2015

[20] Y. A. Wahab and A.S.H. Basari. (2013). “Building maintenance management preliminary finding of a case study in ICYM,” MiddleEast Journal of Scientific Research, Vol. 17, no. 9, pp. 1260-1268